



A Hometown American Product

CATHODIC PROTECTION RECTIFIERS

Universal Rectifiers, Inc.
P.O. Box 1640
1631 Cottonwood School Rd.
Rosenberg, Texas 77471
(281) 342-8471 - (281) 342-0292 Fax:
www.universalrectifiers.com



Air Cooled Standard Line

Air Cooled UT & SW Series

Air Cooled Gas Station Series

Oil Cooled & Explosion Proof Line

ES Utility Line

Watertank Line

Junction Boxes

Model TR-2 (Portable Test Rectifier)

Full line replacement parts

NRTL / ETL
Third Party Certification
available on many models

Air Cooled **Standard Line** Cathodic Protection Rectifiers

Heavy duty, pole mountable, air cooled cathodic protection rectifiers



Type "A" Rectifier

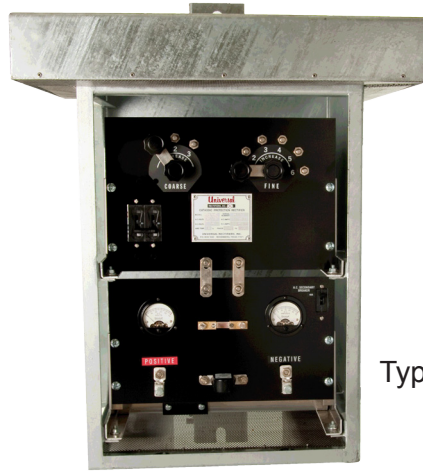

Type "B" Rectifier

The "Standard Line" air cooled, cathodic protection rectifiers are recognized as industry leading in quality, workmanship and service life. Many years of field-proven service prove their superior design. Conservative equipment ratings, controlled manufacturing techniques, plus many extra features ensure long and trouble-free operation.

Typical cathodic protection applications for the air cooled rectifier line include pipelines, tank farms, storage fields, and other non-hazardous locations where continuous duty, DC power is required.

Standard Features Air Cooled **Standard Line**

- Weatherproof to NEMA 3R
- Heavy duty 11-gauge hot dip galvanized cabinet with Stainless Steel Hardware
- Stainless Steel, perforated screens
- Front and side opening doors for easy maintenance
- Heavy duty, draw-pull, stainless steel cabinet latch
- Slide-out equipment racks, separate Transformer and Stack assemblies for units over 1200 watts
- Heavy duty transformer with 15% over-design for reserve capacity
- Minimum 18-step voltage control link bar taps
- Quick-change, heavy-duty knobs for changing tap link bars
- Minimum 5/16" diameter, soldered tap changing studs
- 3/16" Grade XX, Phenolic front panel
- Accessible front panel Total precision shunt
- Magnetic AC Input circuit breaker
- Magnetic AC Secondary Breakers on all units less than 100 amps (instead of fuses)
- Hoyt, separate analog, 2-1/2" round, volt and amp meters
- Silicon diodes protected by surge suppressors and current limiting breakers < 100 Amps or fuses
- All electrical connection hardware is Nickel Plated and double-nutted or soldered
- Multi-strand, high temperature, insulated flexible wiring
- Terminal block for AC input wires
- Primary tap change panel for dual input voltages (Single Phase models only)
- Safety shield panel supplied on all units over 65 Volts DC

Optional Features Air Cooled **Standard Line**

- Variety of AC voltage inputs, Single Phase, Three Phase, 50 or 60 Hertz
- AC and/or DC High Energy lightning protection
- Efficiency filter chokes
- Communication filters
- Meter switches
- Pedestal, base mounting legs, Wall Mount
- Power-on indicator light
- DC failure warning lights
- DC circuit breakers < 100 amps or fuses
- 115 VAC convenience outlet
- Powder-coated cabinet finishes (White or Gray standard)
- Optional cabinet materials, such as aluminum or stainless steel
- Anodized finish for aluminum cabinets
- Anodized finish with clear coat for aluminum cabinets
- Additional voltage control link bar taps
- Alternate output control (constant current, constant voltage, constant potential, and constant potential with IR drop free feature)
- NRTL / ETL third-party certification
- Other options per customer request



Type "A" Rectifier



Type "C" 3 Phase Rectifier



Type "C" 1 Phase Rectifier

Cabinet Wattage & Weight Air Cooled **Standard Line**

	Single Phase		Three Phase	
Case Size	Maximum DC Watts	Shipping Weight	Maximum DC Watts	Shipping Weight
A	1200	135 lbs	-	-
B	2800	185 lbs	1000	225 lbs
C	6000	300 lbs	6500	385 lbs
D	10,000	410 lbs	12,000	625 lbs
E	12,000	525 lbs	18,000	750 lbs

Each rectifier is custom built and will vary in weight:
The weights above are approximate.

Typical Cabinet Dimensions Air Cooled **Standard Line**

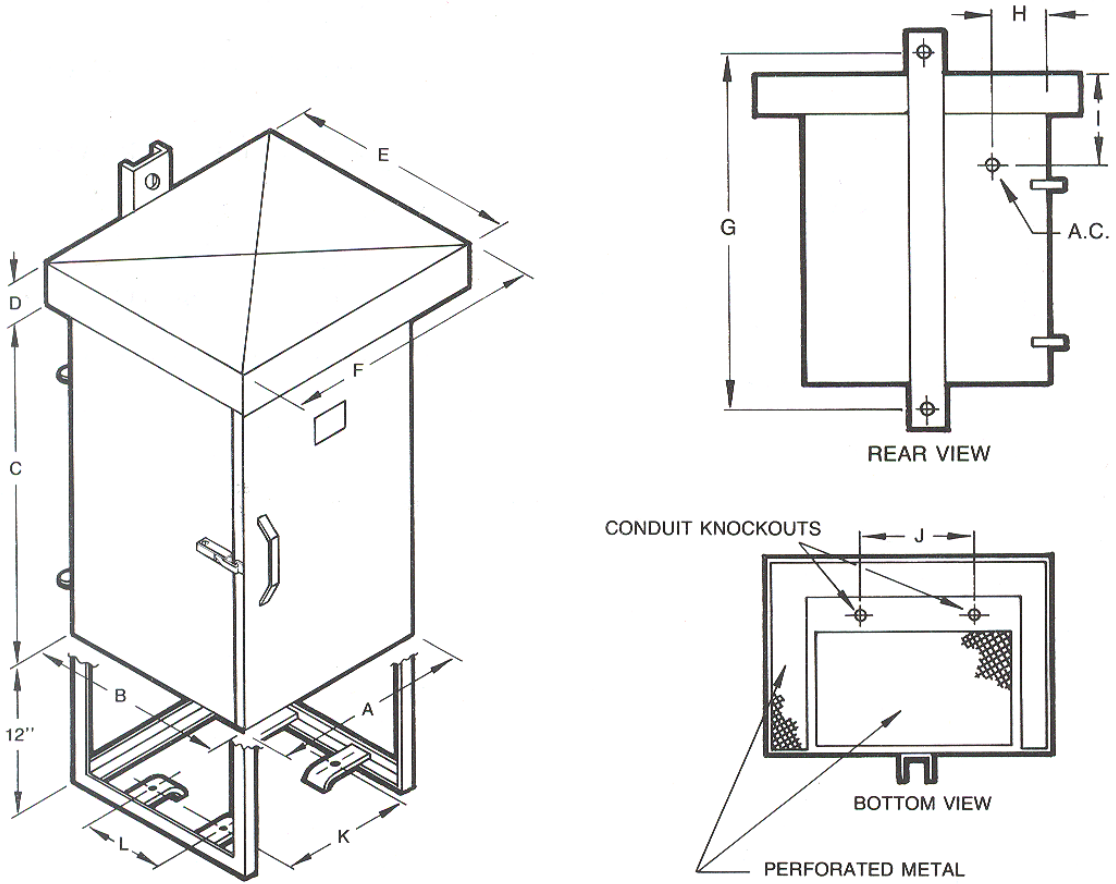

Case Dimensions (inches)

Case Size	A	B	C	D	E	F	G	H	I	J	K	L
A	14.5	12	9.5	3	14.5	19	26.25	3	7.5	6	7.5	3.0
B	17.5	15.5	23.5	3.5	18	23	32	3	9	8	10	6.0
C	22.5	21.5	23.5	3.5	24	28	32	3	9	10	15	10
D	28.5	22.5	23.5	3.5	25	34	32	3	9	12	21	10
E	34	28	33	5	33	44	41.25	3	10.5	14	25	14

Ordering Code / Model Number

Air Cooled **Standard Line**

Position #1: Model

A = Standard Line, Air cooled

Position #2: Type

S = Standard Rectifier (Manual taps)	P = Constant Potential (solid state)
C = Constant Current (Reactor style)	I = Constant Potential IR free (solid state)
D = Constant Current (Solid state)	M = Multiple Modes (Specify Modes Required)
E = Constant Voltage (Solid state)	V = Variac Control

Position #3: Cooling

A = Air Cooled

Position #4: Stack Type

I = Silicon (recommended)

E = Selenium

Position #5: DC Volts

List Maximum DC Voltage Desired

Position #6: DC Amps

List Maximum DC Amperage Desired

Position #7: AC Input

AA = 115/230, 1 phase set for 115 vac	AB = 115/230, 1 phase set for 230 vac
BA = 230/460, 1 phase set for 230 vac	BB = 230/460, 1 phase set for 460 vac
CA = 230/460, 3 phase set for 230 vac	CB = 230/460, 3 phase set for 460 vac
EA = 115/460, 1 phase set for 115 vac	EB = 115/460, 1 phase set for 460 vac
G = 115, 1 phase only	D = 208, 3 phase
H = 230, 1 phase only	F = Specify

Position #8: Special Features

C = AC and DC arrestors	R = 115 VAC convenience outlet
D = DC arrestor	N = Powder coated cabinet (hot-dip galvanized standard on most models)
E = AC arrestor	O = Aluminum cabinet
F = Filter choke	T = Anodized aluminum cabinet
G = Communications filter	U = Anodized aluminum with clear coat
H = Meter switches	P = Additional voltage control link bar taps
I = Base mounting	S = Multiple rectifiers in one case (qty.)
J = Power On indicator light	Q = Other, specify
K = DC failure warning light	
M = DC breaker (> 100 amps) or fuse	

Air Cooled **UT & SW Series** Cathodic Protection Rectifiers

Pole mountable, air cooled cathodic protection rectifiers with swing out and removeable case for superior accessibility for routine maintenance & inspection.

Type "UT" Series

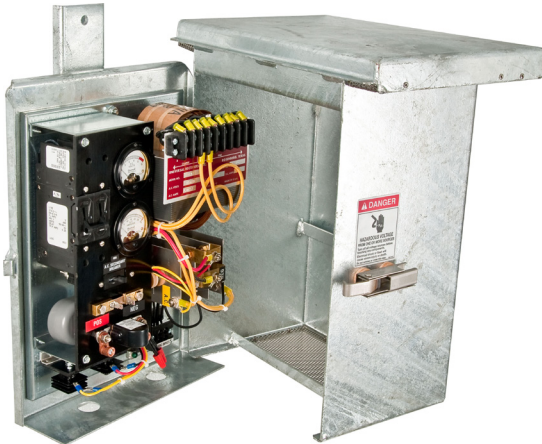

Type "SW" Series

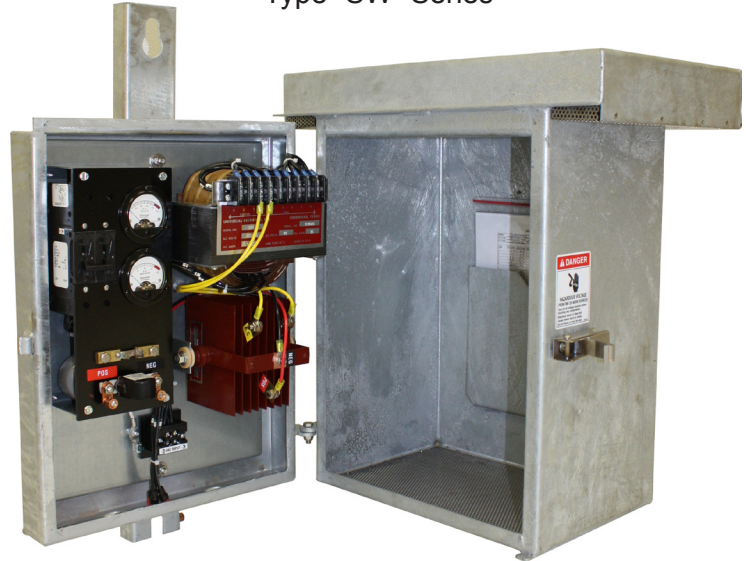

The UT & SW Series air cooled cathodic protection rectifiers, are an alternative to Standard Line series air cooled cathodic protection rectifiers. The UT is the smallest model of the two series with a maximum of 400 watts, with all the same features as the larger SW series. Both Series rectifier features swing out and removable design case, which permits superior accessibility for routine maintenance and inspection. Limited to 1,600 watts of DC output, the simplified rectifier design reduces manufacturing costs and provides an economical rectifier suited for most cathodic protection applications.

Standard Features **UT & SW Series**

- Weatherproof to NEMA 3R
- Heavy duty 11-gauge hot dip galvanized cabinet with Stainless Steel Hardware
- Stainless Steel, perforated screens
- Components mounted on galvanized plate for easy removal
- Heavy duty, draw-pull, stainless steel cabinet latch
- Heavy duty transformer with 15% over-design for reserve capacity
- Minimum 18-step voltage control taps
- 3/16" Grade XX, Phenolic front panel
- Accessible front panel Total precision shunt
- Magnetic AC Input circuit breaker
- Magnetic AC Secondary Breakers (instead of fuses)
- Hoyt, separate analog, 2-1/2" round, volt and amp meters
- Silicon diodes protected by surge suppressors and current limiting breakers
- All electrical connection hardware is Nickel Plated and double-nutted or soldered
- Multi-strand, high temperature, insulated flexible wiring
- Terminal block for AC input wires
- Safety shield panel supplied on all units over 65 Volts DC

Optional Features

Air Cooled **UT & SW Series**

- A variety of AC voltage inputs single phase only
- AC and/or DC High Energy lightning protection
- Efficiency filter chokes
- Communication filters
- Meter switches
- Power-on indicator light
- DC circuit breakers
- 115 VAC convenience outlet
- Powder coated cabinet finishes (White or Gray Standard)
- Additional voltage control adjustments
- Other options per request of customer

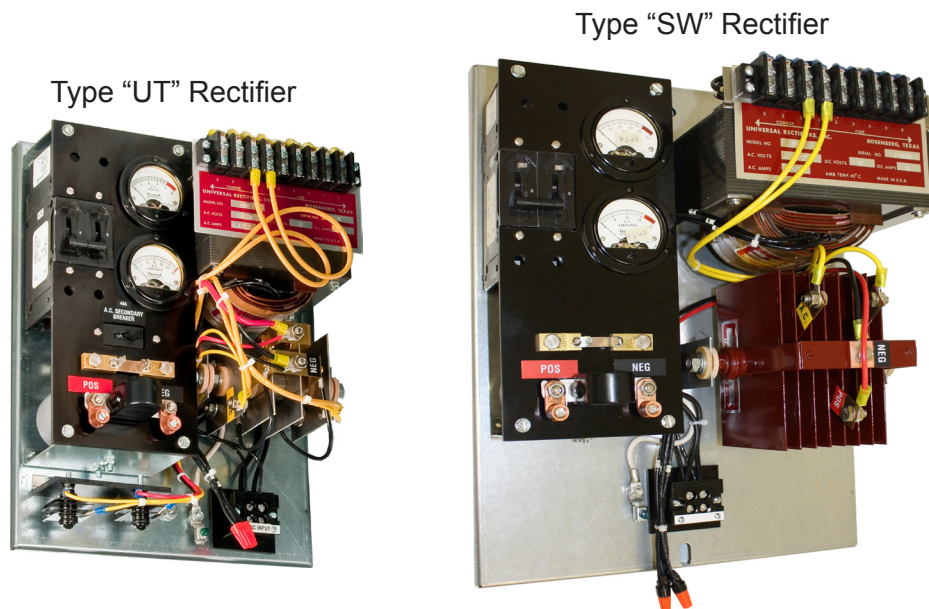

Cabinet Wattage & Weight

Case Size	Maximum DC Watts	Shipping Weight
UT	400	80 lbs
SW1	800	110 lbs
SW2	1200	150 lbs
SW3	1600	200 lbs

Each rectifier is custom built and will vary in weight:
The weights above are approximate.

Typical Cabinet Dimensions Air Cooled **UT & SW Series**

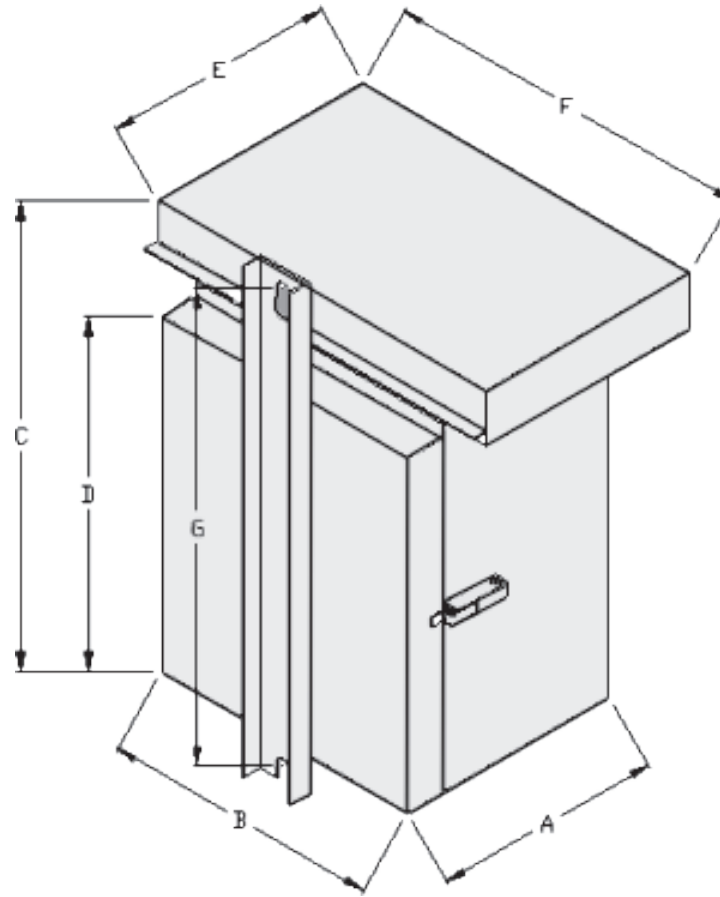

Dimensions (inches)

Case Size	A	B	C	D	E	F	G
UT	8.75	12	19	17	11	16	20
SW1	12	15	22	18.5	12	20	25
SW2	14	17	25	22	14.5	22	28
SW3	14	20	28	25.5	14.5	25	31

Ordering Code / Model Number

Air Cooled **UT & SW Series**

Position #1: Model

S = SW Series Air Cooled Rectifier

U = UT Series Air Cooled Rectifier

Position #2: Type

S = Standard Rectifier (Manual taps)

V = Variac Control

Position #3: Cooling

A = Air Cooled

Position #4: Stack Type

I = Silicon (recommended)

E = Selenium

Position #5: DC Volts

List Maximum DC Voltage Desired

Position #6: DC Amps

List Maximum DC Amperage Desired

Position #7: AC Input

AA = 115/230, 1 phase set for 115 vac	AB = 115/230, 1 phase set for 230 vac
BA = 230/460, 1 phase set for 230 vac	BB = 230/460, 1 phase set for 460 vac
EA = 115/460, 1 phase set for 115 vac	EB = 115/460, 1 phase set for 460 vac
G = 115, 1 phase only	H = 230, 1 phase only
F = Specify	

Position #8: Special Features

C = AC and DC arrestors	M = DC breaker or fuse
D = DC arrestor	R = 115 VAC convenience outlet
E = AC arrestor	N = Powder coated cabinet (hot-dip galvanized standard on most models)
F = Filter choke	P = Additional voltage control taps
G = Communications filter	Q = Other, specify
H = Meter switches	
J = Power On indicator light	

Air Cooled Gas Station Series Cathodic Protection Rectifiers

Low-cost CP rectifiers limited to 1,500 watts of DC output



Gas Station Series

The “Gas Station Series” air cooled cathodic protection rectifier, is a low-cost rectifier option with the same reliability as the standard air cooled rectifier line. Limited to 1,500 watts of DC output, this smaller rectifier is used for applications such as gas stations, pipelines, storage tanks or other non-hazardous locations where continuous duty, DC power is required.

Standard Features Gas Station Series

- Weatherproof to NEMA 3R
- 16-gauge, White powder coated cabinet with front opening door
- Wall mounting tabs top and bottom (pole mount Channel is optional)
- Heavy-duty transformer with 15% over-design for reserve capacity
- Heavy duty, draw-pull, stainless steel cabinet latch
- Slide-out galvanized chassis
- 20-step voltage control with link bar taps
- Hinged 3/16” Grade XX, Phenolic front panel
- Accessible front panel Total precision shunt
- AC Input circuit breaker
- Magnetic AC Secondary Breakers (instead of fuses)
- Hoyt, separate analog, 2-1/2” round, volt and amp meters
- Time elapsed indicating meter
- Silicon diodes protected by surge suppressors and current limiting breakers
- All electrical connection hardware is Nickel Plated and double-nutted or soldered
- Multi-strand, high temperature insulated flexible wiring
- Terminal block for AC input wires
- Safety shield panel supplied on all units over 65 Volts DC

Optional Features

Air Cooled Gas Station Series

- AC and/or DC lightning protection
- Communication filters
- Meter switches
- AC/DC failure light
- DC circuit breakers
- 115 VAC convenience outlet
- Alternate output control (constant current, constant voltage, constant potential)
- NRTL / ETL third party certification
- Other options per request of customer

Standard Gas Station Series

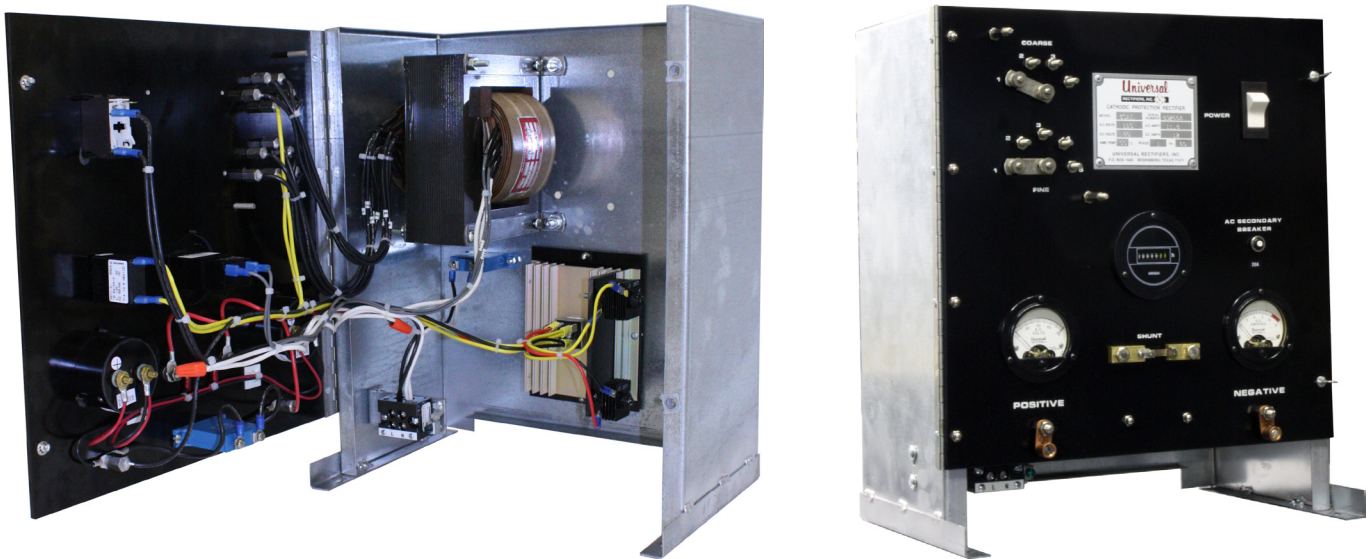

Cabinet Wattage & Weight

Case Size	Maximum DC Watts	Shipping Weight
Pro-1	1000	100 lbs
Pro-2	1500	150 lbs

Each rectifier is custom built and will vary in weight:
The weights above are approximate.

Typical Cabinet Dimensions Air Cooled Gas Station Series

NEMA 3R
POWDER COATED WHITE

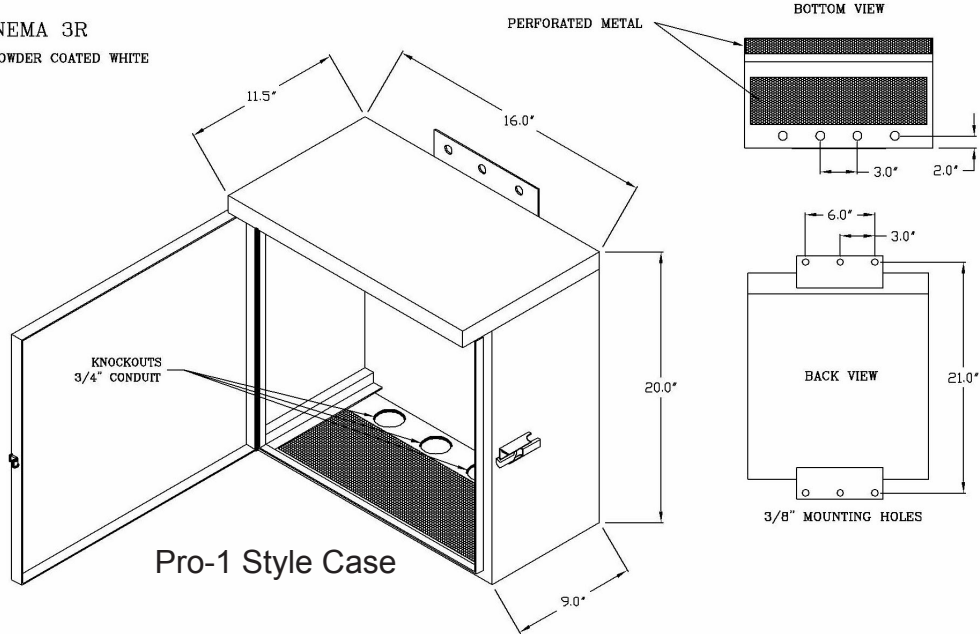

NEMA 3R
POWDER COATED WHITE

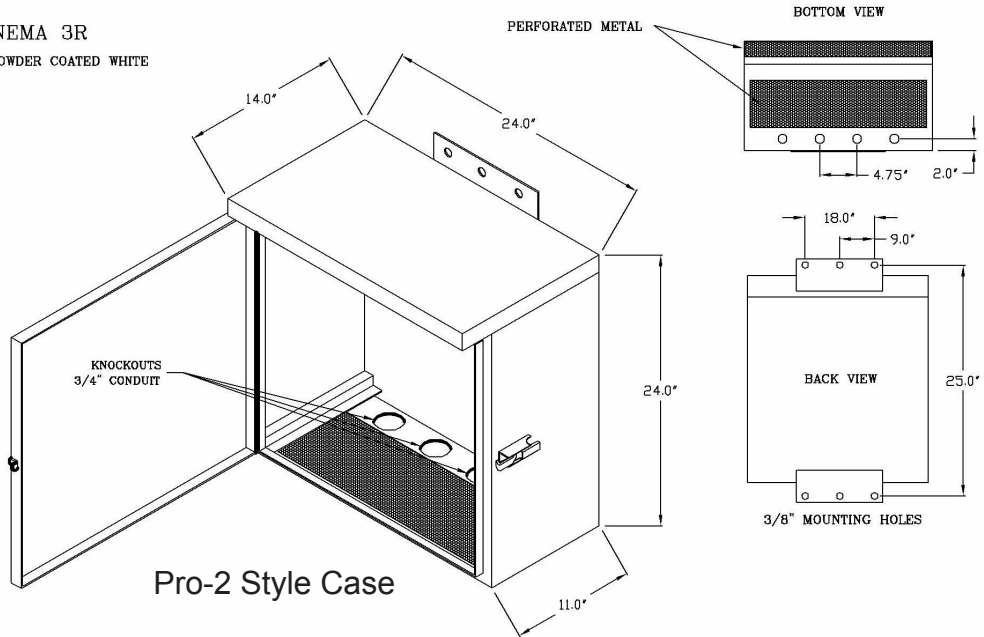

Ordering Code / Model Number

Air Cooled Gas Station Series

Position #1: Model

G = Gas Station Series

Position #2: Type

S = Standard Rectifier (Manual taps)	P = Constant Potential (solid state)
C = Constant Current (Reactor style)	M = Multiple Modes (solid state)
D = Constant Current (Solid state)	V = Variac Control
E = Constant Voltage (Solid state)	

Position #3: Cooling

A = Air Cooled

Position #4: Stack Type

I = Silicon

Position #5: DC Volts

List Maximum DC Voltage Desired

Position #6: DC Amps

List Maximum DC Amperage Desired

Position #7: AC Input

G = 115, 1 phase only

Position #8: Special Features

C = AC and DC arrestors	J = Power On indicator light
D = DC arrestor	K = DC failure warning light
E = AC arrestor	M = DC breaker
G = Communications filter	R = 115 VAC convenience outlet
H = Meter switches	Q = Other, specify

Oil Cooled & Explosion Proof Cathodic Protection Rectifiers

Heavy-duty, rugged rectifiers for operation under severe conditions



The “oil cooled” cathodic protection rectifiers, are recognized as industry leading in quality, workmanship and service life. Many years of field-proven service have led to the superior design of these rectifiers. Conservative equipment ratings, controlled manufacturing techniques, plus many extra features ensure long and trouble-free operation.

Typical cathodic protection applications for the oil cooled rectifier line include severe environmental conditions due to high humidity, dust, or other situations that would shorten the life of a standard air cooled rectifier.

Explosion proof models are used for Class 1, Group D locations and comply with U.L. Standard 698. While similar to the standard oil cooled rectifiers, the explosion proof units are fitted with special hazardous area fittings to eliminate possibility of an ignition source.

Standard Features Oil Cooled & Explosion Proof

- Weatherproof to NEMA 3R.
- Heavy duty 11 gauge hot dip galvanized cabinet with hinged top lid and stainless steel hardware.
- External cabinet fins for added strength and cooling.
- Heavy duty, draw-pull, stainless steel cabinet latches.
- Separate instrument compartment with hinged door and stainless steel hardware.
- Separate lift-out component racks for the transformer and rectifier stack.
- Heavy duty transformer with 15% over design for reserve capacity.
- Minimum 18-step voltage control link bar taps.
- Quick-change heavy duty knobs for changing tap link bars.
- Minimum 5/16” diameter, solder tap changing studs
- 3/16” Grade XX, Phenolic panels
- AC Input circuit breaker
- Magnetic AC secondary circuit breakers on all units less than 100 amps (instead of fuses)
- Hoyt, separate analog, 2-1/2” round, volt and amp meters
- Silicon diodes protected by surge suppressors and current limiting breakers < 100 Amps or fuses
- All electrical connection hardware is Nickel Plated and double-nutted or soldered
- Multi-strand, high temperature, insulated flexible wiring
- Terminal block for AC input wires (Non-Hazardous models only)

Optional Features

Oil Cooled & Explosion Proof

- Variety of AC voltage inputs, Single Phase, Three Phase, 50 or 60 Hertz
- AC and/or DC High Energy lightning protection
- Efficiency filter chokes.
- Communication filters.
- Meter switches
- Power-on indicator light
- DC failure warning lights
- DC circuit breakers < 100 amps or fuses
- 115 VAC convenience outlet
- Optional cabinet materials, such as stainless steel
- Additional voltage control link bar taps.
- Alternate output control (constant current, constant voltage, constant potential, and constant potential with IR drop free feature.
- Powder coated cabinet finishes over galvanized coating (White or Gray Standard)
- Other options per request of customer.

Type "AO" Standard

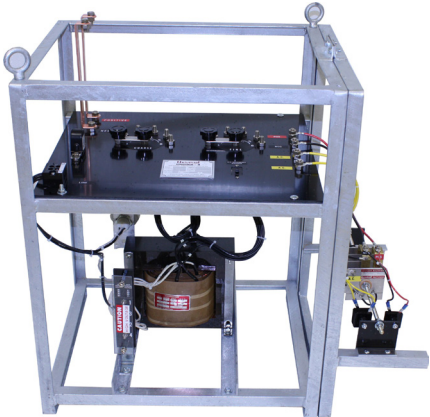

Type "AO"
Three Phase



Type "AO"
Single Phase

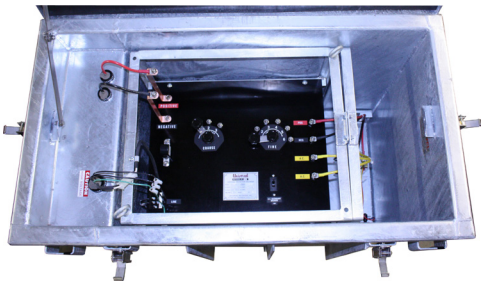

Cabinet Oil Capacity, Wattage & Weight

Oil Cooled & Explosion Proof

	Single Phase		Three Phase		
Case Size	Oil Capacity US Gallons	Maximum DC Watts	Shipping Weight	Maximum DC Watts	Shipping Weight
MAO	20	500	200 lbs	-	-
AO	55	501-1900	450 lbs	0-3600	518 lbs
BO	110	1901-3400	594 lbs	3601-6400	660 lbs
CO	165	3401-4250	731 lbs	6401-8000	860 lbs
DO	213	4251-5300	935 lbs	8001-10000	1100 lbs
EO	300	5301-6400	1020 lbs	10001-12000	1200 lbs
FO	465	6401-8500	1200 lbs	12001-16000	1400 lbs
GO	600	8501-10600	1400 lbs	16001-20000	1600 lbs

Each rectifier is custom built and will vary in weight:
The weights above are approximate.

Typical Cabinet Dimensions Oil Cooled & Explosion Proof

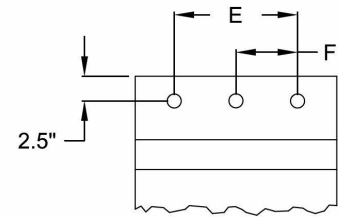
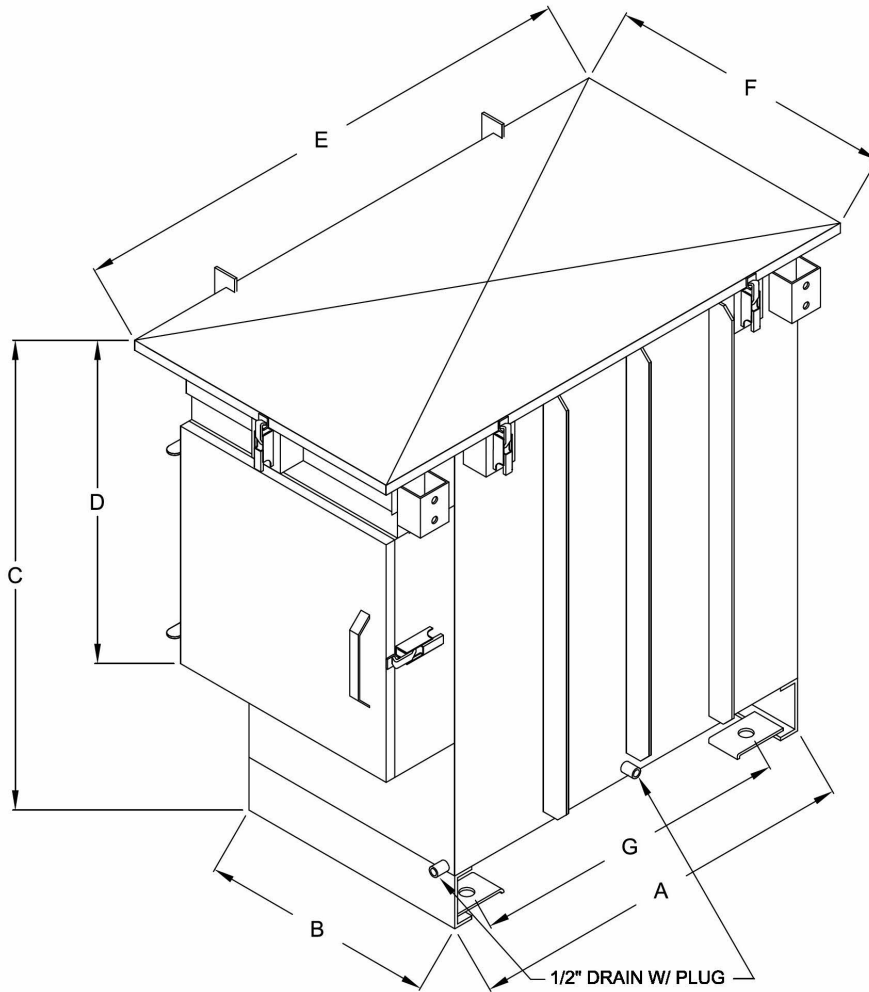

STANDARD KNOCKOUT DETAIL
(BOTTOM VIEW)

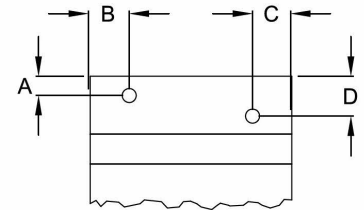

EXPLOSION PROOF KNOCKOUT DETAIL
(BOTTOM VIEW)



STUD LOCATION FOR TIE-DOWN CLIPS
1/2" STUDS RECOMMENDED

Case Dimensions & Stud Location (inches)

Knockout Detail

Case Size	A	B	C	D	E	F	G	H	A	B	C	D	E	F
* MAO	17.5	15	24.5	20	27	18.25	13	12	3	1.75	3.5	4	8	4
AO	30	18	34.75	25	39.75	22	24.5	15	3	3	3.5	4	8	4
BO	36	21	47	25	46	25	30	18	3	3	3.5	4.25	10	5
CO	48	21	53	25	58	25	42	18	3	3	3.5	4.25	10	5
DO	60	21	53	25	70	25	54	18	3	3	3.5	4.25	10	5
EO	72	21	53	25	82	25	66	18	3	3	3.5	4.25	10	5
FO	84	30.5	53	25	94	34	78	27	3	3	3.5	4.25	10	5
GO	84	30.5	65	25	94	34	78	27	3	3	3.5	4.25	10	5

* MAO - Shipped with 12" tall stand

Ordering Code / Model Number

Oil Cooled & Explosion Proof

Position #1: Model

O = Standard Line, Oil cooled

Position #2: Type

S = Standard Rectifier (Manual taps)	P = Constant Potential (solid state)
C = Constant Current (Reactor style)	I = Constant Potential IR free (solid state)
D = Constant Current (Solid state)	M = Multiple Modes (Specify Modes Required)
E = Constant Voltage (Solid state)	V = Variac Control

Position #3: Cooling

O = Oil Cooled Standard

X = Oil Cooled XP (Hazardous Location) Class 1, Div. 2

Position #4: Stack Type

I = Silicon (recommended)

E = Selenium

Position #5: DC Volts

List Maximum DC Voltage Desired

Position #6: DC Amps

List Maximum DC Amperage Desired

Position #7: AC Input

AA = 115/230, 1 phase set for 115 vac	AB = 115/230, 1 phase set for 230 vac
BA = 230/460, 1 phase set for 230 vac	BB = 230/460, 1 phase set for 460 vac
CA = 230/460, 3 phase set for 230 vac	CB = 230/460, 3 phase set for 460 vac
EA = 115/460, 1 phase set for 115 vac	EB = 115/460, 1 phase set for 460 vac
G = 115, 1 phase only	D = 208, 3 phase
H = 230, 1 phase only	F = Specify

Position #8: Special Features

C = AC and DC arrestors	K = DC failure warning light
D = DC arrestor	M = DC breaker (> 100 amps) or fuse
E = AC arrestor	R = 115 VAC convenience outlet*
F = Filter choke	P = Additional voltage control link bar taps
G = Communications filter	S = Multiple rectifiers in one case (qty.)
H = Meter switches*	Q = Other, specify
J = Power On indicator light	

* = For Standard Oil Cooled Rectifiers Only

ODR Oil Cooled & Explosion Proof Cathodic Protection Rectifiers

Rugged smaller rectifiers for lower output applications under severe conditions
Maximum 200 watts & 20 amps single phase

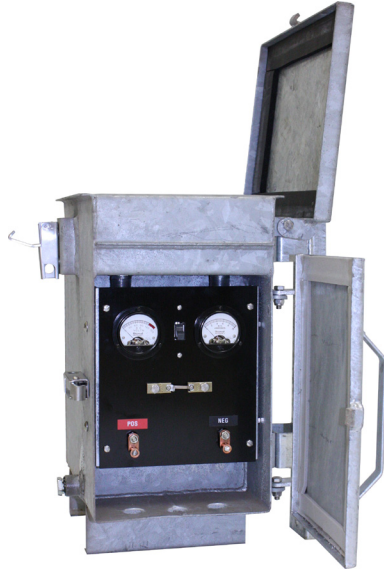

Type "ODR" Standard

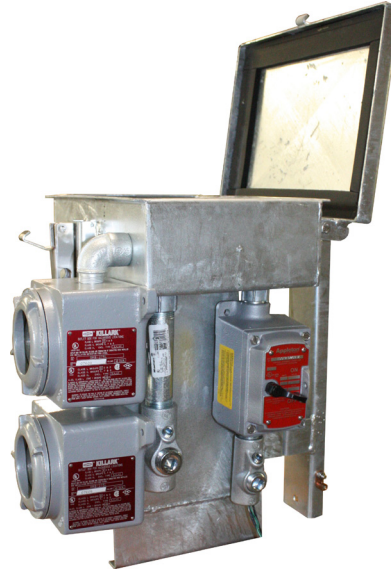

Type "ODR" Explosion Proof

Standard Features

ODR Oil Cooled & Explosion Proof

- Weatherproof to NEMA 3R.
- Heavy duty 11 gauge hot dip galvanized cabinet with hinged top lid and stainless steel hardware.
- Heavy duty, draw-pull, stainless steel cabinet latches.
- Wall mount, Pole mount, or Pad mount
- Separate instrument compartment with hinged door and stainless steel hardware.
- Lift-out component rack for the transformer and rectifier stack.
- Heavy duty transformer with 15% overdesign for reserve capacity.
- Minimum 18-step voltage control terminal strip taps.
- 3/16" Grade XX, Phenolic panels
- AC Input circuit breaker
- Magnetic AC secondary circuit breakers (instead of fuses)
- Hoyt, separate analog, 2-1/2" round, volt and amp meters
- Silicon diodes protected by surge suppressors and current limiting breakers
- All electrical connection hardware is Nickel Plated and double-nutted or soldered
- Multi-strand, high temperature, insulated flexible wiring
- Terminal block for AC input wires (Non-Hazardous models only)

Optional Features

ODR Oil Cooled & Explosion Proof

- Variety of AC voltage single phase inputs, 50 or 60 Hertz
- AC and/or DC High Energy lightning protection
- Communication filters.
- Meter switches - (Non Hazardous model only)
- Power-on indicator light
- DC failure warning lights
- DC circuit breakers
- Additional voltage control adjustments
- Powder coated cabinet finishes over galvanized coating (White or Gray Standard)
- Other options per request of customer.

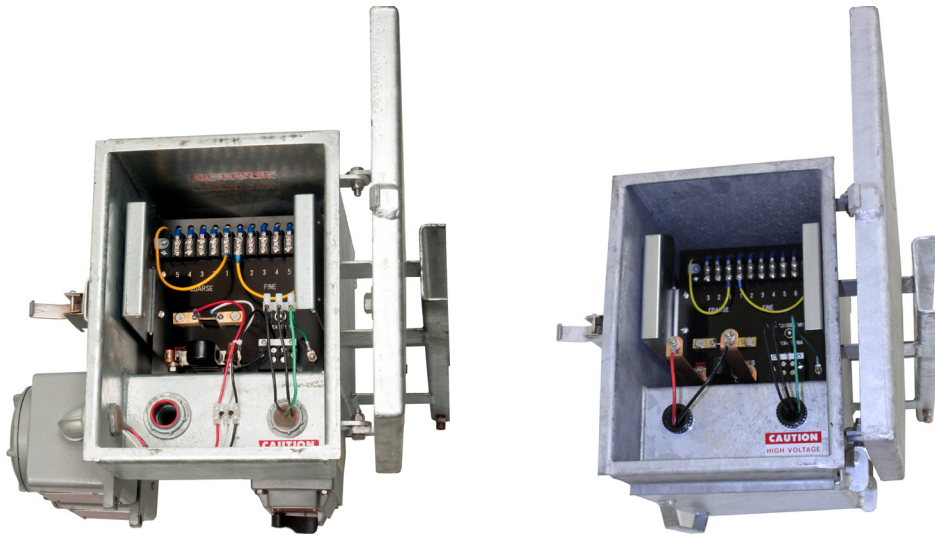
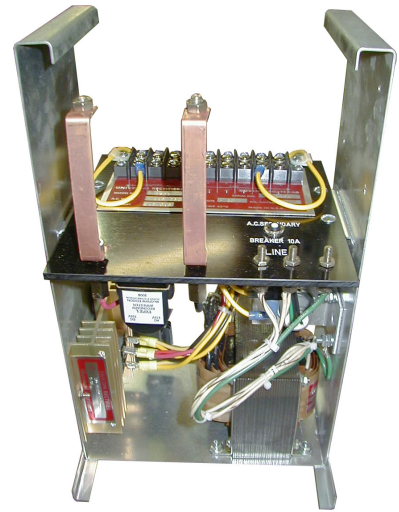

Cabinet Oil Capacity, Wattage & Weight

Oil Cooled & Explosion Proof

Single Phase

Case Size	Oil Capacity US Gallons	Maximum DC Watts	Shipping Weight
ODR	3.5	200	90 lbs

Typical Cabinet Dimensions

ODR Oil Cooled & Explosion Proof

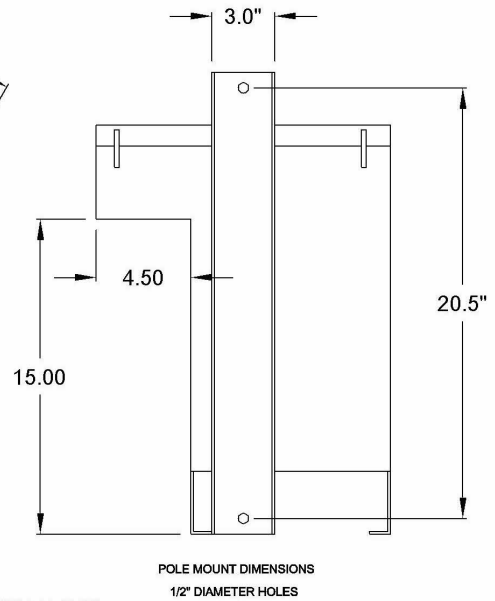
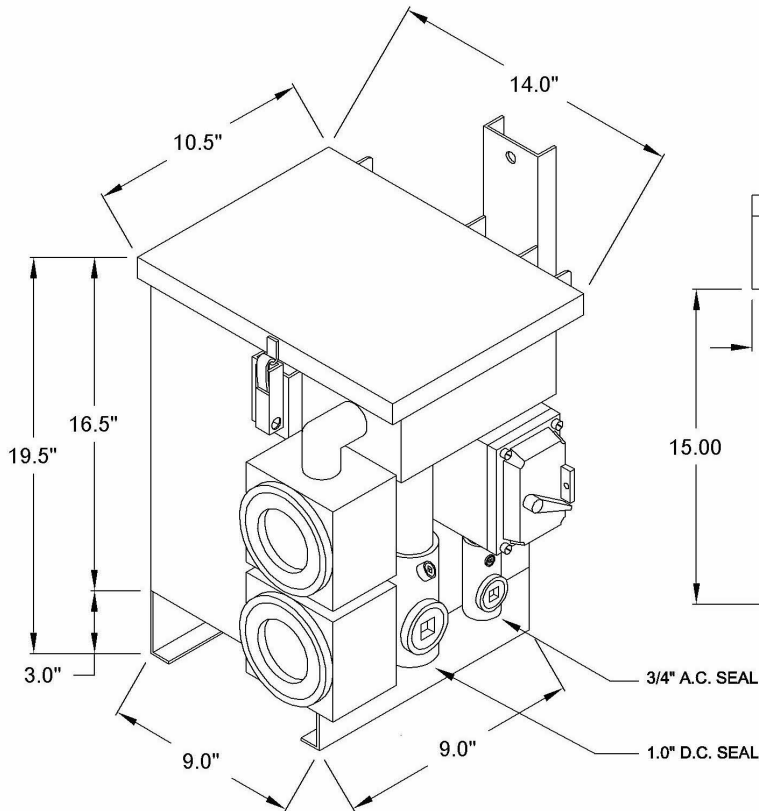
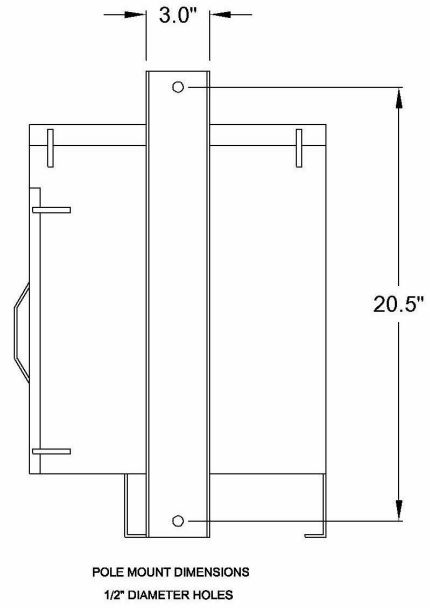
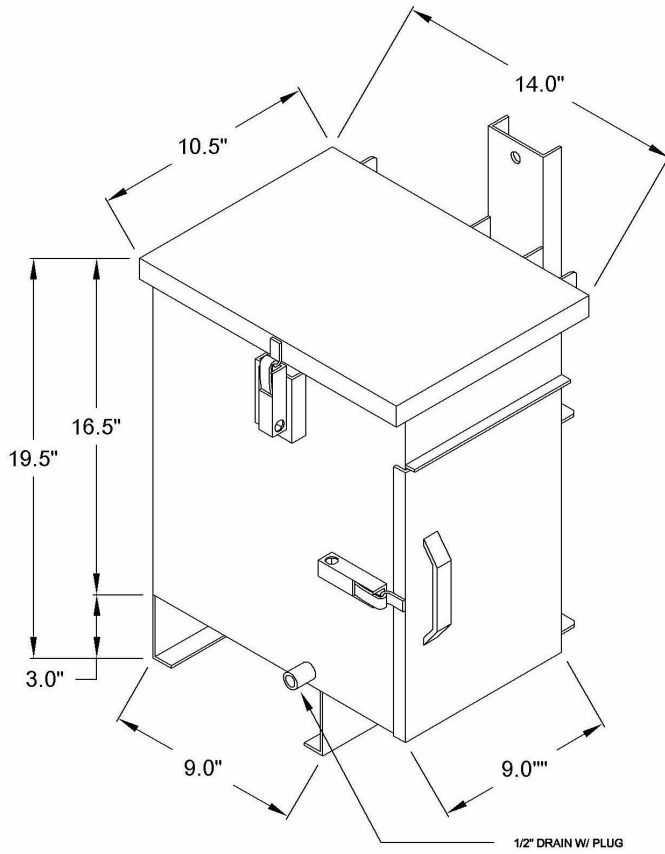

Ordering Code / Model Number

Oil Cooled & Explosion Proof

Position #1: Model	
D = ODR Series, Oil Cooled	
Position #2: Type	
S = Standard Rectifier (Manual taps)	
V = Variac Control	
Position #3: Cooling	
O = Oil Cooled Standard	
X = Oil Cooled XP (Hazardous Location) Class 1, Div. 2	
Position #4: Stack Type	
I = Silicon (recommended)	
E = Selenium	
Position #5: DC Volts	
List Maximum DC Voltage Desired	
Position #6: DC Amps	
List Maximum DC Amperage Desired	
Position #7: AC Input	
AA = 115/230, 1 phase set for 115 vac	AB = 115/230, 1 phase set for 230 vac
BA = 230/460, 1 phase set for 230 vac	BB = 230/460, 1 phase set for 460 vac
EA = 115/460, 1 phase set for 115 vac	EB = 115/460, 1 phase set for 460 vac
G = 115, 1 phase only	H = 230, 1 phase only
Position #8: Special Features	
C = AC and DC arrestors	K = DC failure warning light
D = DC arrestor	M = DC breaker
E = AC arrestor	P = Additional voltage control link bar taps
G = Communications filter	Q = Other, specify
H = Meter switches*	
* = For Standard Oil Cooled Rectifiers Only	

Air Cooled **ES Line** Cathodic Protection Rectifiers

Low output, low cost, lightweight cathodic protection rectifiers for underground storage tanks and other low DC power cathodic protection applications
maximum 200 watts & 10 amps

Standard Features **ES-I Line**

- 120V AC single phase input only
- All Circuit breakers - No Fuses
- Heavy duty aluminum case for post or wall mount
- Unique opening cabinet for total access to components
- Assembly only 13" high x 5" wide x 5.5" deep
- Ammeter only
- 18-step voltage control taps
- Silicon rectifying elements
- AC and DC lightning protection
- AC input terminal block
- Accessible front panel Total precision shunt
- Standard outputs: 6V-5A, 6V-10A, 12V-5A, 12V-10A, 20V-5A, 20V-10A, 30V-5A, 40V-5A.
- Other outputs available not exceeding 200W and 10A

Model ES-I Rectifier



Model ES-II Rectifier



Standard Features **ES-II Line**

- 120V AC single phase input only
- All Circuit breakers - No Fuses
- Heavy duty aluminum case for post or wall mount
- Metering viewing windows
- Unique opening cabinet for total access to components
- Assembly only 13" high x 7.5" wide x 5.5" deep
- Voltmeter and ammeter
- 18-step voltage control taps
- Silicon rectifying elements
- AC and DC lightning protection
- AC input terminal block
- Accessible front panel Total precision shunt
- Standard outputs: 6V-5A, 6V-10A, 12V-5A, 12V-10A, 20V-5A, 20V-10A, 30V-5A, 40V-5A.
- Other outputs available not exceeding 200W and 10A

Typical Cabinet Dimensions Air Cooled ES-I & ES-II Line

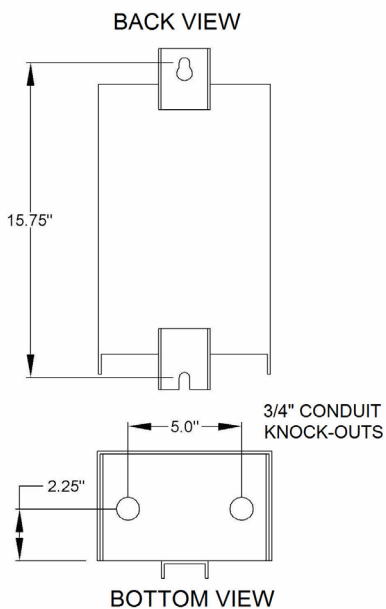
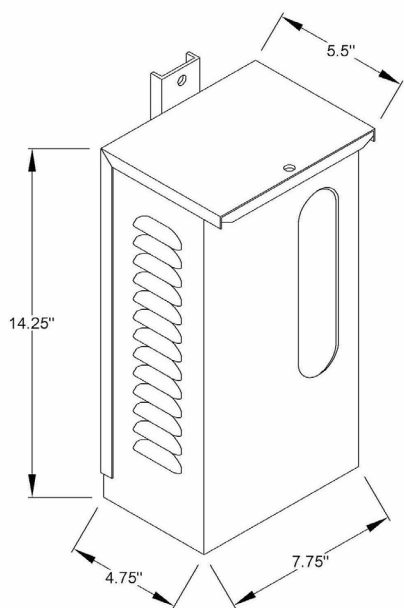
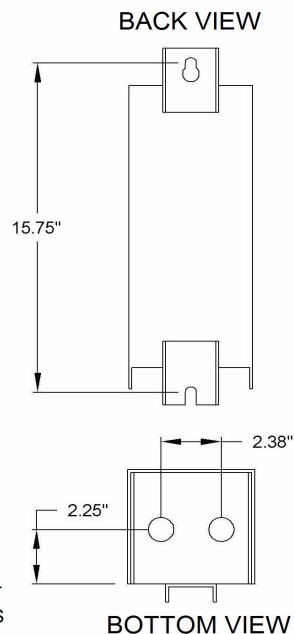
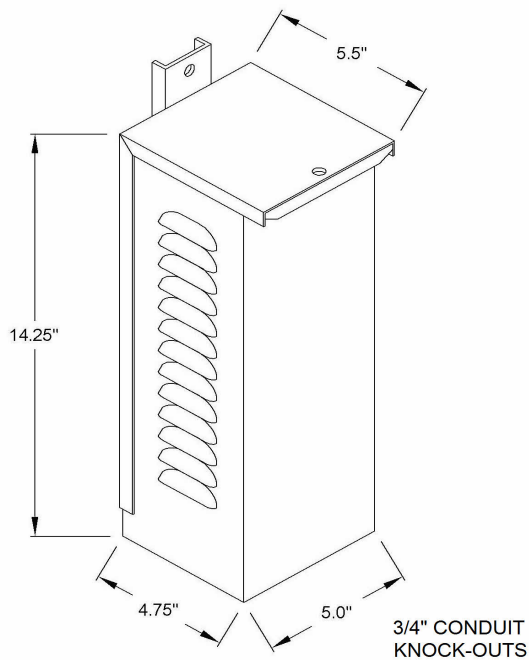

Optional Features Air Cooled **ES-I & ES-II Line**



ES-I with Variac Control

ES-I Line

- Variac Control
- NRTL / ETL third party certification

ES-II Line

- Variac Control
- NRTL / ETL third party certification
- Hour Meter
- Red/Green DC failure light
- Solid state controller, Current Control, Voltage Control, or Auto Potential Control



ES-II with Optional Controller

Ordering Code / Model Number Air Cooled **ES Line**

Position #1: Model

ES-I = ES Utility Rectifier

ES-II = ES Utility Rectifier

Position #2: Output Control Type

S = Standard Rectifier (Manual taps)

V = Variac Control

E = Constant Voltage Control (ES-II only)

D = Constant Current Control (ES-II only)

P = Constant Potential Control (ES-II only)

M = Multiple Modes (ES-II only)

Position #3: DC Output Voltage*

List DC Voltage Desired (See available ratings below)

Position #4: DC Output Current*

List DC Current Desired (See available ratings below)

Position #5: Special or Optional Features

H = Hour Meter (ES-II only)

K = Red or Green Status Lights (ES-II only)

* Standard Ratings

6 Volt - 5 Amp
12 Volt - 5 Amp
20 Volt - 5 Amp
30 Volt - 5 Amp

6 Volt - 10 Amp
12 Volt - 10 Amp
20 Volt - 10 Amp
40 Volt - 5 Amp

Air Cooled **Watertank Line** Cathodic Protection Rectifiers

Low output, low cost, lightweight cathodic protection rectifiers for underground storage tanks and other low DC power cathodic protection applications
maximum 200 watts & 10 amps

The “W” series auto potential controlled rectifier is specifically designed for the Water Tank Industry. Using proven, dependable solid state control boards to maintain strict “Standard On” or “I.R.Free” potentials. Easy read Bright LED Digital meters for accurate readings of volts, amps and potentials. This compact, light weight rectifier can easily be mounted on tank walls or posts by one person.



IR Free Potential Watertank



Standard Potential Watertank

Standard Features **Watertank Line**

- Nema 4x Diamond Shield CSA Approved enclosure with “Solarguard” double UV protection
- Stainless steel hinge and latches.
- All major components mounted on an aluminum chassis with Universal’s unique cooling design.
- Non conductive shock resistant front panel for safety
- All Circuit Breakers - No Fuses
- Universal’s proven solid state potential control circuit with built in voltage and current control modes.
- Fully protected input and output circuits with fast-acting re-settable circuit breakers (NO FUSES).
- Separate Digital LED meters for volts, amps and potential w/ amp readings down to 10 milliamps
- All readings can be verified from front panel.
- Accessible front panel Total precision shunt
- Hinged front panel for easy access to components
- Multiple reference cell operation with built in reference cell failure shut down.
- Automatic or Manual operation.
- Versatile mounting for post, rack or wall
- Most models weighing less than 35 pounds.
- Wide range of output ratings available.

Optional Features Air Cooled **Watertank Line**

- Standard Potential or IR Drop Free Potential
- Potential Monitor with Red & Green Lights
- AC & DC Lighting Protection
- Riser Circuit with 50 Watt 22 Ohm Rheostat, Shunt & Breaker



Watertank Potential Monitor
with red & green lights

Typical Cabinet Dimensions Air Cooled **Watertank Line**

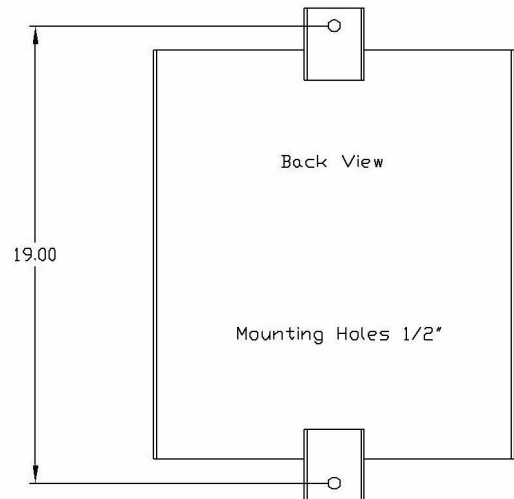
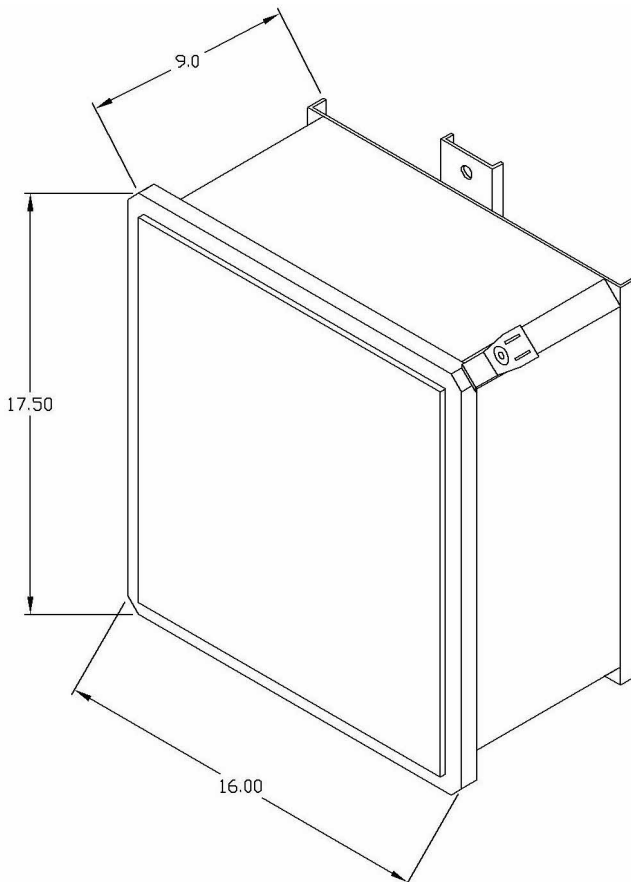

Ordering Code / Model Number

Air Cooled **Watertank Line**

Position #1: Model

W = Watertank

Position #2: Output Control Type

P = STD. Potential

I = IR Free Potential

Position #3: Type

A = Air Cooled

Position #4 Stack Type

I = Silicon

Position #5: DC Output Voltage*

List DC Voltage Desired (See available ratings below)

Position #6: DC Output Current*

List DC Current Desired (See available ratings below)

Position #7: Special or Optional Features

G = 115 VAC Single Phase 60 Hertz

C = AC & DC Lighting Arrestors

K = Potential Monitor (Red & Green Status Lights)

S = Riser Ckt with 50 watt 22 Ohm Rheostat,
Shunt, & Breaker

* Standard Ratings

12 Volt - 5 Amp
12 Volt - 10 Amp
20 Volt - 5 Amp
20 Volt - 10 Amp

30 Volt - 5 Amp
20 Volt - 8 Amp
40 Volt - 5 Amp
Special rating consult factory



Watertank internal
component view

Junction Boxes For Cathodic Protection Rectifiers

Custom heavy duty and lightweight junction boxes for cathodic protection rectifiers



Enclosures Available

Fiberglass (standard)
Galvanized Hot-dip 11ga
Aluminum / Anodized
Stainless Steel

Galvanized 16ga (standard)
Aluminum
Aluminum / Anodized / Clear coat
Explosion Proof (cast aluminum)

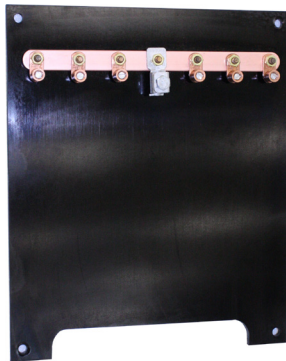

- Box Model TB**
- 6 ckt
 - KPA-25 Header lug
 - KA-4C circuit lugs

- Model TB-SR**
- 6 ckt
 - RS Shunts (5 amp)
 - KPA-25 Header Lug
 - KA-4C circuit lugs
 - 50 watt - 1 ohm resistors

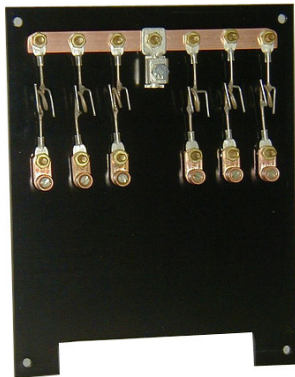

- Anode Terminal Box
Model TB-S**
- 6 ckt
 - RS Shunts (5 amp)
 - KPA-25 Header lug
 - KA-4C circuit lugs

- Model TB-SR**
- 6 ckt
 - Resistors
 - SS Shunts (25 amp)
 - KPA-25 Header lug
 - KA-4C circuit lugs
 - 50 watt - 1 ohm resistors

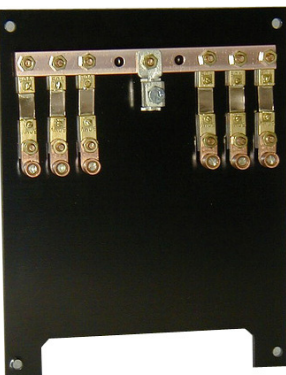

- Model TB-S**
- 6 ckt
 - SW Shunts (50 amp)
 - KPA-25 Header lug
 - KA-4C circuit lugs

- Model TB-SR**
- 6 ckt
 - SW Shunts (50 amp)
 - KPA-25 Header lug
 - KA-4C circuit lugs
 - Space / 50 watt resistor

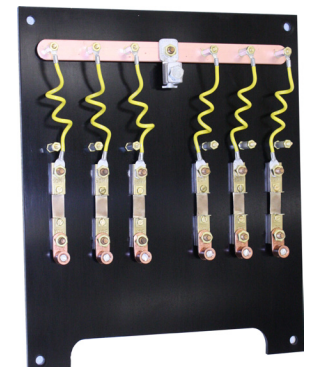

Ordering Code / Model Number

Junction Box

Features

TYPE

TB = Terminal only
TB-S = Terminals & Shunts
TB-SR = Terminals, Shunts & Resistors

ENCLOSURE (Suggested nema 3r when using resistors)

Fiberglass (standard)	Nema 4x
Galvanized 16ga (standard)	Nema 3r
Galvanized Hot-dip 11ga	Nema 3r
Aluminum	Nema 3r or 4x (specify)
Aluminum / Anodized	Nema 3r or 4x (specify)
Aluminum / Anodized / Clear coat	Nema 3r or 4x (specify)
Stainless Steel	Nema 4x
Explosion Proof (cast aluminum)	Class 1 Div. 1
Note: Nema 3r (vented)	Nema 4x (sealed)

SHUNT TYPE and RATING

RS (wire shunt)	5 amps
SS (stainless steel)	25 amps
SW (brass block)	5, 10, 15, 20, 25, 30, 50, 75, 100, 200 amps

TERMINAL LUG SIZE

KA-4C = #14 - #4 wire
KPA-25 = #4 - 1/0 wire
KPA-28 = 1/0 - 4/0 wire

RESISTORS (1-ohm standard)

25 watt - 1-ohm	5.0 amps max.
50 watt - 1-ohm	7.07 amps max.
100 watt - 1-ohm	10.0 amps max.
300 watt 1-ohm	17.3 amps max.
Space Only (for future resistor or resistance wire)	

SPECIAL FEATURES

Rheostats (Specify size - Watts / Ohm)
Ammeter with switch
Conduit knock-outs in box (Specify size & qty.)
Specify other

JUNCTION BOX ORDER FORM

Type of Junction Box	TB-S
Number of Circuits: <small>header lug is not counted as a circuit</small>	6
Enclosure & Nema Rating	Fiberglass 4x
Shunt Type & Rating	RS 5amp
Header Lug Size	KPA-25
Circuit Lug Size	KA-4C
Resistor Watt / Ohm	None
Special Features	None

The features listed to the left, cover our typical junction boxes. Contact us if you have special requirements.

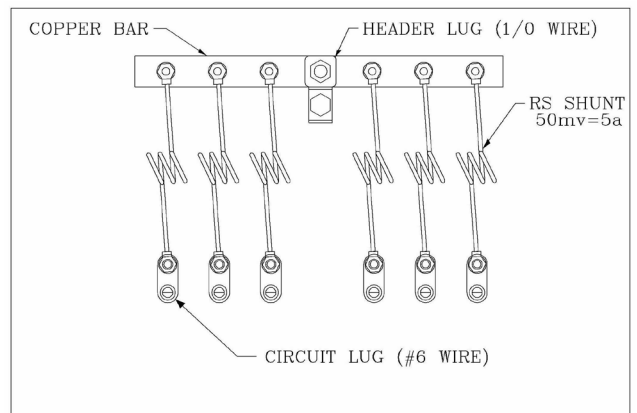

One of many configurations available.

Air Cooled **Model TR-2** Cathodic Protection Rectifiers

A portable cathodic protection power supply with 60V,
30A DC output and a built-in solid state interrupter.



The Universal Rectifier model TR-2 air cooled cathodic protection test rectifier, is a portable cathodic protection power supply used for a variety of CP field test scenarios. Provided with a 60 volt, 30 amp maximum DC output in 18 steps of adjustment, and solid state variable interrupter, the TR-2 is capable of providing a wide range of portable DC power.

Standard Features **Model TR-2**

- DC output of 60 volts, 30 amps
- Tool box style cabinet with carrying handle
- 24" long x 9" high x 8" deep
- Approximately forty-five (45) pounds
- 18-step voltage control link bar taps
- Solid state timer relay for interruption
- Accessible front panel Total precision shunt
- Magnetic AC Input circuit breaker
- Magnetic AC Secondary Breakers (instead of fuses)
- Hoyt model 17-3 volt and amp meters
- All electrical connections are double-nutted or soldered

Replacement Parts Air Cooled & Oil Cooled Cathodic Protection Rectifiers

A complete line of industry standard components for replacement purposes.

Rotary and Toggle Switches

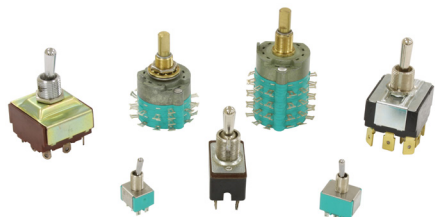

Knobs & Pointer Knobs



Rheostats



Variac Controls

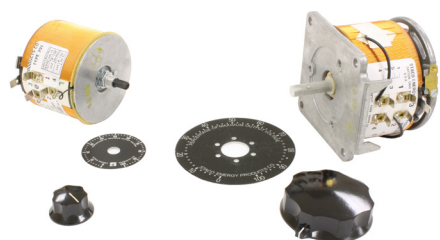

Contactors & Relays

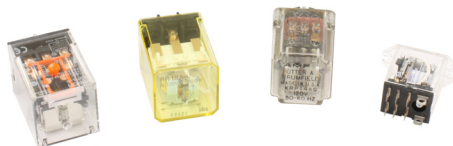

Resistors

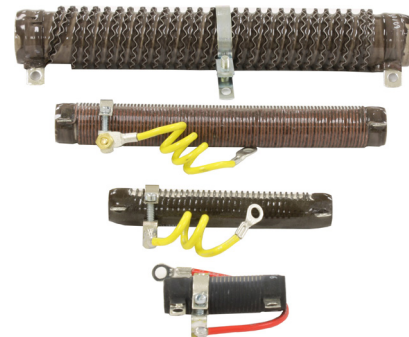

Test Load Resistors

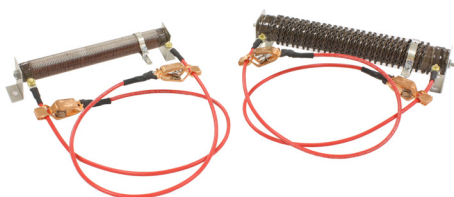

Clamp-on & Voltage Detectors



Test Load Breakers



Solid State Controllers

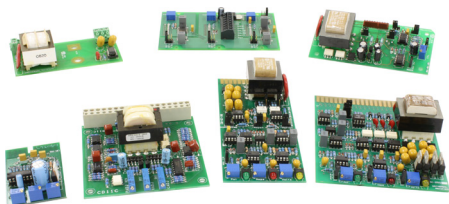

Shunts

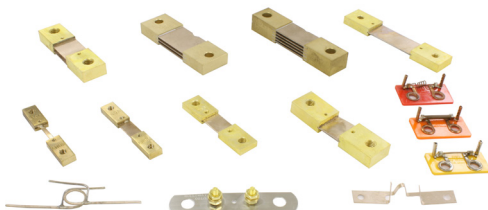

Timers & Light Relays

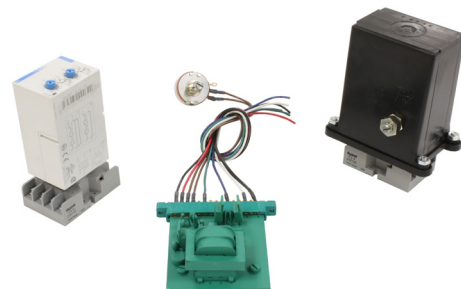

Replacement Parts Air Cooled & Oil Cooled Cathodic Protection Rectifiers

A complete line of industry standard components for replacement purposes.

Selenium Bridges

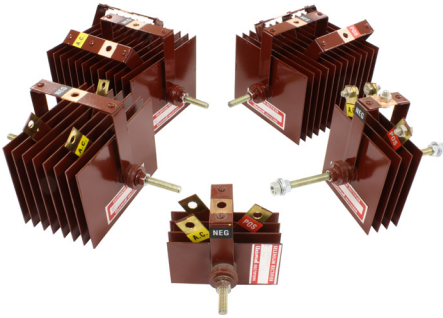

Aluminum Plate Bridges

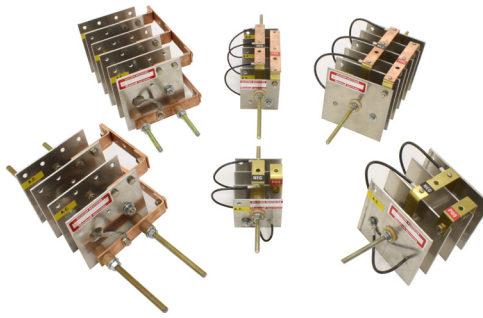

Heatsink Bridges

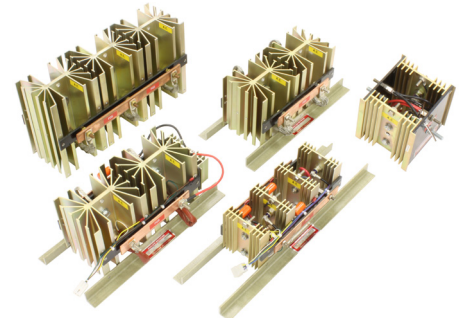

Bolt-on & Snap-in Fuses



Diodes & SCR's

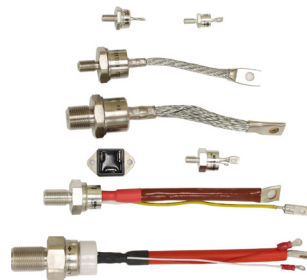

Bridge Modules



Circuit Breakers



Lightning Arrestors



Meters



Other parts available:

Transformers
Panel
Capacitors

Filter Chokes
Wire

Quick Change Knobs & Link Bars

Universal Rectifiers, Inc.
P.O. Box 1640
1631 Cottonwood School Rd.
Rosenberg, Texas 77471
(281) 342-8471 - (281) 342-0292 Fax:
www.universalrectifiers.com

Sales: Mike Hill
mikehill@universalrectifiers.com
Tech. Support: Mike Speck
mikespeck@universalrectifiers.com
Tech. Support: Mike Llamas
mikellamas@universalrectifiers.com